



MirroSky Series SP127 Smart Telescope



[Setup Video](#)



[Latest Manual](#)



[Customer Service](#)



[Visit Our Website](#)



INTRODUCTION	2
WARNINGS	2
PARTS LIST	3
OPTIONAL ACCESSORIES	3
MAJOR COMPONENTS.	3
SETUP GUIDE	5
HOME POSITION SENSORS	7
ALIGNING THE OTAS	7
SOLAR WARNING	7
FOCUSING THE OTA.	8
GETTING READY	9
CONNECTING TO THE TELESCOPE.	10
HOW TO USE IN AZ MODE	11
TERRESTRIAL VIEWING	11
CELESTIAL VIEWING / IMAGING	12
DARK FRAMES	15
THE DESKTOP CLIENT.	16
MAINTENANCE	17
SPECIFICATIONS	18
WARRANTY	19
RETURN POLICY	19
CUSTOMER SERVICE	19



The MirroSky SkyPilot 127, also known as the SP127, is a groundbreaking modular smart telescope designed for both visual observation and astrophotography. With the SP127, you can simultaneously view celestial objects through the eyepiece and capture stunning images of the same target, an exclusive feature unmatched by any other smart telescope on the market.

At the heart of the SP127 is the MirroSky Intelligent Camera System, which powers its advanced imaging capabilities. Featuring a high-performance Sony IMX662 color CMOS sensor, a premium 53mm ED (extra-low dispersion) optic, and the user-friendly MirroSky app with a database of over 100,000 celestial objects, this system can automatically locate, track, guide, and image targets with ease. The 53mm ED scope can function as your primary imaging telescope or serve as a secondary finder/guide scope—it's entirely up to you.

The SkyPilot 127's main optical tube features a compact 127mm Maksutov-Cassegrain design with fully multi-coated optics and a long focal length, ideal for viewing planets, galaxies, nebulae, and star clusters in sharp detail.





We at Spectrum Optics are certain the SP127 will bring years of night sky enjoyment by removing the complications of locating, guiding, and imaging the night sky and letting you spend more time viewing its celestial wonders.



If during your explorations you have questions regarding the use of our products, please feel free to contact our highly trained staff who can assist you quickly.

To get you started with your night sky adventures, we recommend reading through this manual to learn about all the exciting features the SP127 has to offer. A SP127 setup video is also available at https://www.youtube.com/@spectrum_optics

The SP127 carries a Two-Year Limited Warranty, honored by Spectrum Optical Instruments. For details, please see our warranty at https://spectrumoi.com/refund_returns/.

WARNINGS

 WARNING		
 	<ul style="list-style-type: none">• INGESTION HAZARD: This product contains small parts.• INGESTION HAZARD: This product contains a button cell or coin battery.• DEATH or serious injury can occur if ingested.• A swallowed button cell or coin battery can cause INTERNAL CHEMICAL BURNS in as little as 2 HOURS.• Ensure PROPER SUPERVISION and keep small parts OUT OF REACH OF CHILDREN.• SEEK IMMEDIATE MEDICAL ATTENTION if a small part or a coin battery is suspected to be swallowed or inserted inside any part of the body.	 

 SOLAR WARNING	
<ul style="list-style-type: none">• Solar observations require SPECIAL PRECAUTIONS to ensure the safety of both your eyes and your equipment.• The Sun emits intense and POTENTIAL HARMFUL RADIATION, including ultraviolet and infrared light.• Observing the Sun without proper solar rated gear can lead to IRREVERSIBLE DAMAGE to your eyes and equipment.	



SP AZ Mount	x1	MS Intelligent Camera	x1
127mm Maksutov-Cass. OTA	x1	53mm ED OTA w/ Bracket	x1
1.25" 90° Diagonal	x1	1.25" 25mm Plössl Eyepiece	x1
Full-Size Tripod	x1	53mm Bahtinov Focus Mask	x1
USB-C Cable	x2	AC Adapter	x1
USB-C to 5.5mm Adapter	x1	Instruction Manual	x1

OPTIONAL ACCESSORIES

Smartphone Adapter with Bluetooth	x1	Universal Phone Adapter	x1
		Aspherical Eyepiece Set	x1

MAJOR COMPONENTS



Fig. 1.1



Fig. 1.2

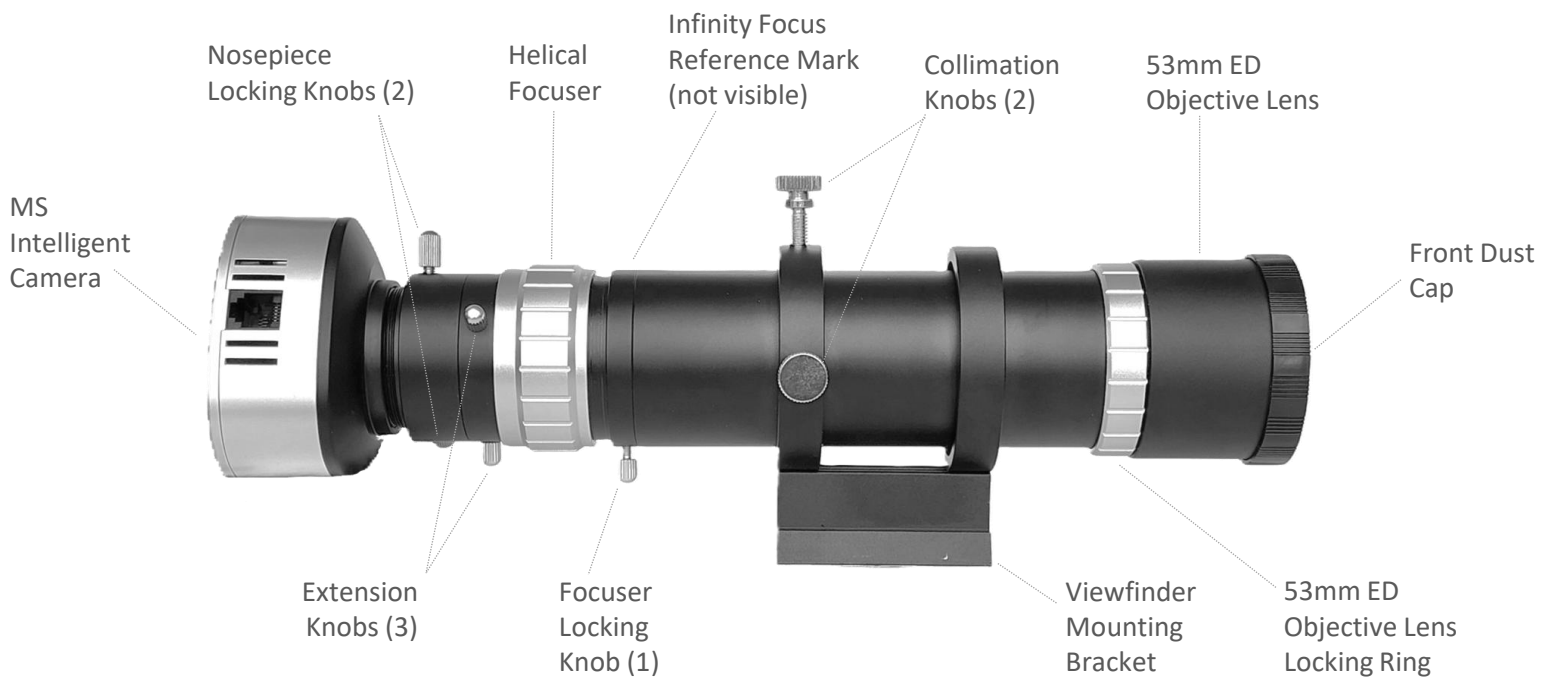

Fig. 1.3

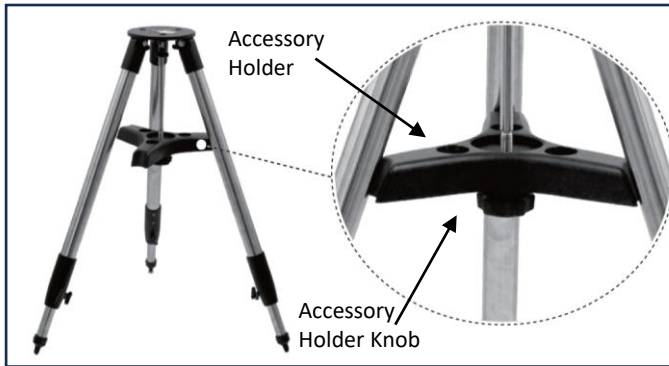

Fig. 2.1

1. Take the tripod and the accessory holder out of the package and place it onto a level surface. Next, fully spread the tripod legs outward to their widest position.
2. Unthread and remove the accessory holder knob and washer from the center shaft. Slide the accessory holder onto the center rod with the flat side toward the ground. Reinstall the washer and accessory holder knob and tighten to a firm feel. The accessory tray should contact each leg as shown in Fig. 2.1.

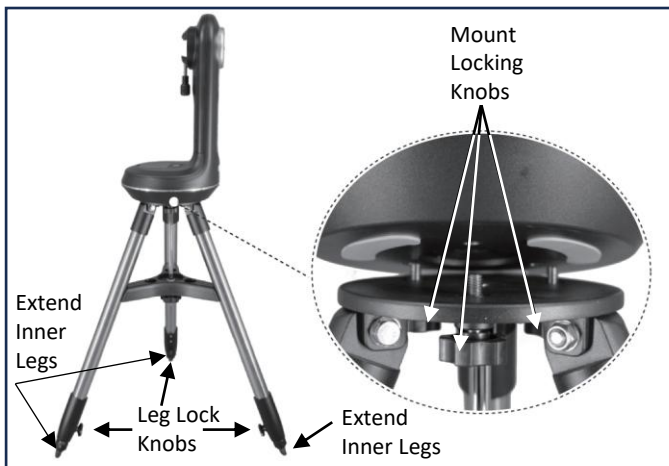

Fig. 2.2

3. Take the mount out of the package and carefully place it onto the top of the tripod. Attach the mount to the tripod using the three spring loaded mount locking knobs. Tighten the three mount locking knobs until firm. See Fig. 2.2.
4. Loosen the tripod leg lock knobs and adjust the height of the tripod by extending each inner leg as shown in Fig. 2.2. Set the telescope to the desired height and adjust each leg as necessary until the bubble in the bubble-level is centered, confirming the telescope is level. Tighten each leg lock knob to a firm feel.

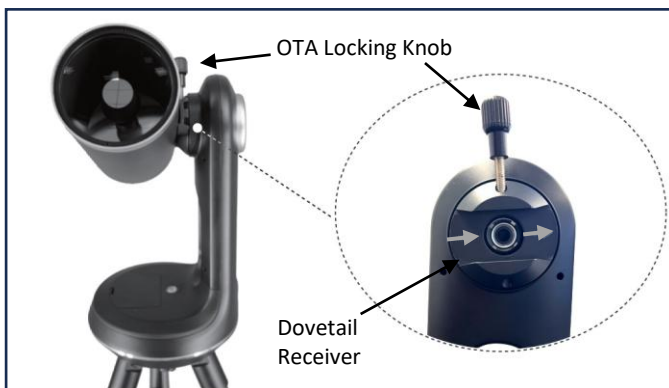

Fig. 2.3

5. Remove the 127mm Maksutov-Cassegrain OTA from the package and slide the OTA into the dovetail receiver, making sure the OTA is pointing in the direction shown on the dovetail receiver. See Fig. 2.3. The OTA locking knob should line up with the indicator line etched on the Vixen dovetail to ensure the altitude axis is balanced. Note there is no altitude lock knob, and the altitude system can be moved manually by force without causing damage to the system.

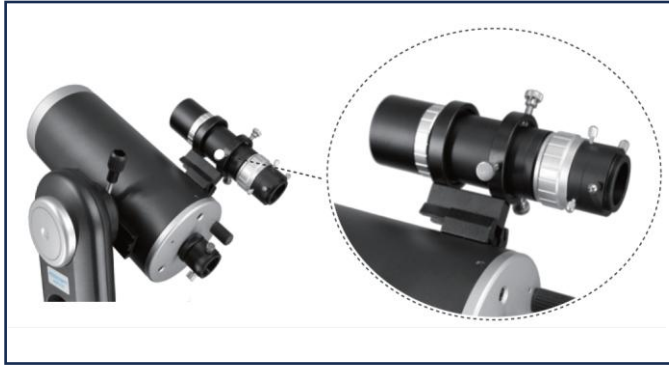

Fig. 2.4



Fig. 2.5

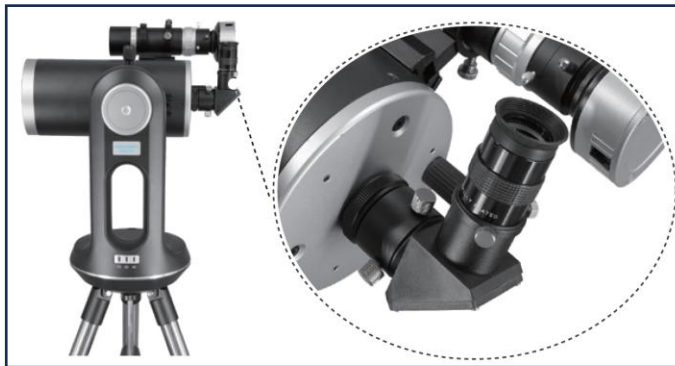

Fig. 2.6



Fig. 2.7

6. Install the 53mm ED OTA onto the 127mm optical tubes viewfinder bracket with the lens facing forward. Secure it in place by tightening the viewfinder bracket locking knob until firm. See Fig. 2.4.

7. Remove the dust caps from the Intelligent Camera nosepiece and both ends of the 53mm and 127mm OTAs.

8. Insert the MS Intelligent Cameras nosepiece into the 53mm OTA's focuser with the "TOP" label facing up. Tighten the two nosepiece locking knobs to secure it. See Fig. 2.5.

9. Install the 90-degree diagonal into the rear of the 127mm optic and secure with the locking knob. Next, install the eyepiece into the 90-degree diagonal and tighten the eyepiece locking knob. See Fig. 2.6.

Note: If planning to image through the 127mm optic, a third-party camera is recommended. The MS Intelligent Camera is designed for use with OTA's of 70mm and smaller with a focal ratio of f/6 or less. The 127mm Maksutov-Cassegrain is an f/15 which makes the field of view too small and not ideal for the plate-solving technology used by the MS Intelligent Camera. If you use a third-party camera, the best placement is directly into the visual back and not using the 90-degree diagonal.

10. Connect the camera to the mount with the included USB-C cable. One end of the cable goes to the USB-C port (marked as "Power" on the camera, and the plug other end into the camera port  located on the mount. See Fig. 2.7.

11. Plug the included AC adapter into the wall outlet, and plug the other end into the power port  located on the mount. If preferred, you may use any power bank that supplies 12V power or 8 AA batteries. See Fig. 3.3 & 3.4 on page 10.



Home Position Sensors



Fig. 2.8

1. The telescope is equipped with electronic sensors in each axis that allow it to locate its starting home position automatically. When ready to use the telescope, it is best to start with the OTA pointing downward, below the level position (see Fig. 2.8). If not below level, the altitude axis can be moved manually with force, without causing damage to the drive.
2. Power on the telescope using the on/off switch located as shown and each axis will rotate to locate its home position sensors.

Note: The altitude axis will only move in the upward direction to find level. Placing this axis below level will allow it to locate the level position more quickly. If the ota is pointing above level, it will rotate more than 180 degrees to find level and the camera cable can become tangled.

Aligning the OTAS

Before proceeding, please see the sections titled “**Getting Ready**” and “**How to Use in AZ Mode: Terrestrial Viewing**” on pages 9-11. This will walk you through downloading the MirroSky APP, connecting to the telescope, and moving the telescope using the APP. After, return to this section to align the OTAs.

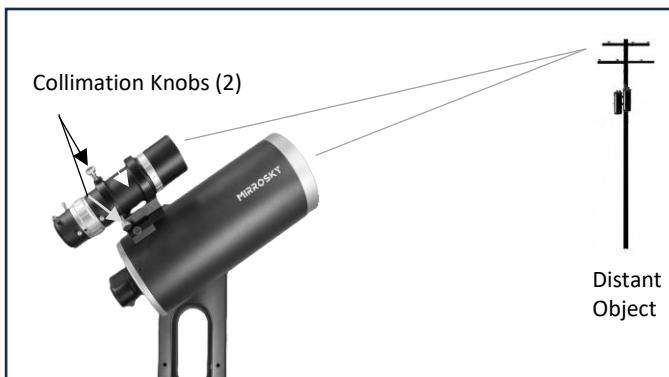

Fig. 2.9

1. For best results, both OTAs need to be pointing at the same object. This requires aligning the 53mm OTA and 127mm OTA using the collimation knobs.
2. During the daytime, point the 127mm OTA at a distant target such as a streetlamp or utility pole. Focus the OTA by turning the focus knob and center the object in the field of view. See Fig. 2.9.
3. Focus the 53mm optic until the image is sharp (see page 8). Then adjust the 53mm OTA by only using the OTA collimation knobs so it is looking at the same object as the 127mm OTA. Now when an object is viewed in one telescope, it will also appear in the other. If needed, more precise alignment can be done on the night sky.
4. When ready to use the telescope on the night sky, point the OTA slightly downward from level before powering on so the auto-homing feature can find the level position quickly. See the section on Home Position Sensors for more information.

SOLAR WARNING

<ul style="list-style-type: none"> Solar observations require SPECIAL PRECAUTIONS to ensure the safety of both your eyes and your equipment. The Sun emits intense and POTENTIAL HARMFUL RADIATION, including ultraviolet and infrared light. Observing the Sun without proper solar rated gear can lead to IRREVERSIBLE DAMAGE to your eyes and equipment. 	
---	--



Focusing the OTA

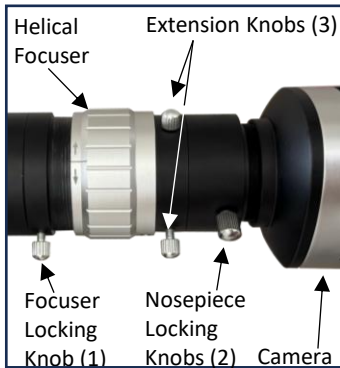

Fig. 2.10



Fig. 2.11

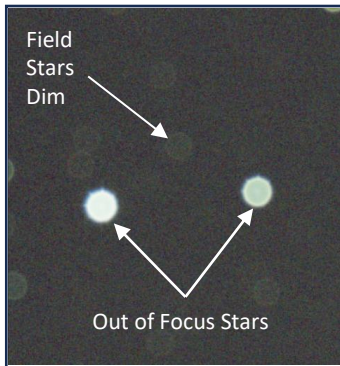

Fig. 2.12

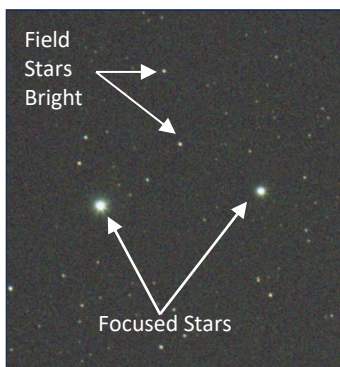

Fig. 2.13

The included 53mm ED OTA features a helical focuser with approximately 16 mm of travel. To focus, loosen the focuser locking knob and rotate the silver focuser ring until the image appears sharp (see Figures 2.10 and 2.11).

For daytime use, rotating the focuser counterclockwise (looking from the back of the telescope) brings nearby objects in focus, while rotating the focuser clockwise will focus more distant objects.

For night sky use, the telescope may not be set to infinity focus. To quickly approximate focus, use the etched reference marks on the focuser. See Fig. 2.11.

First, loosen the focuser locking knob (Fig. 2.10) located in front of the helical focuser. Then, rotate the focuser until the etched line and edge of focuser ring (Fig. 2.11) are aligned and have no gap between them. This will get you close to infinity focus.

To focus the 127mm Maksutov-Cassegrain optics, it is best to start with the included 25mm eyepiece installed. This provides a wider field of view and brighter image.

Point to a bright object such as a distant object, the moon, or a bright star. Turn the 127mm OTAs focus knob until the image is sharp. The 127mm has a narrow field of view and a large range of focus travel so multiple turns of the knob might be needed. When near focus, turn the knob slowly until the image is sharp and stars are as small and bright as possible. Please note the focus may change throughout the night as the temperature changes or when changing eyepieces.

Next, fine-tune focus of the 53mm optic by adjusting the focuser while observing a bright star. Out-of-focus stars will appear large, blurry, and dim (Fig. 2.12); continue adjusting until the brightest star appears as small, sharp, and as bright as possible (Fig. 2.13).

As focus improves, fainter field stars will also become visible. Once focus is achieved, re-tighten the focuser locking knob until secure.



Focusing the OTA CONT'D

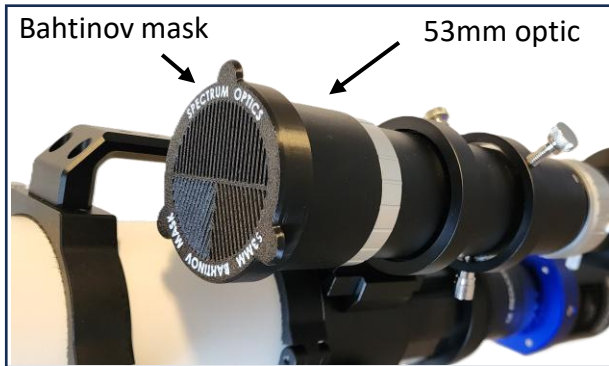

Fig. 2.14

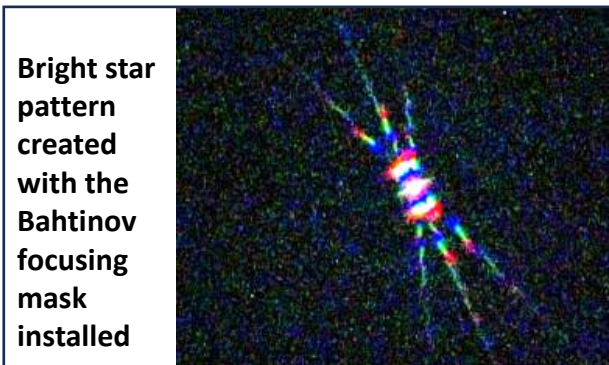

Fig. 2.15

Using the Bahtinov Focusing Mask

The Bahtinov mask fits over the front of the 53mm optic and is used only when focusing the camera. See Fig. 2.14. Dark frames aren't needed for focusing.

1. Point the telescope at a very bright star high in the sky. Use an exposure of about 2-3 seconds and gain of about 100.
2. Place the Bahtinov mask over the front of the 53mm optic. The Bahtinov mask creates an "X" pattern with a central line. The brighter the star, the better.
3. Adjust the focuser until the central line bisects the "X" evenly. Zoom in using the app for precise alignment. See Fig. 2.15. When focused remove the mask.
4. For detailed instructions on using the Bahtinov Focusing Mask, scan the QR code or click the hyperlink below.

[Bahtinov Mask Instructions](#)



GETTING READY



Fig. 3.1



Fig. 3.2

1. Scan the QR Code (Fig. 3.1) to download the MirroSky APP (Fig. 3.2) or search "MirroSky" and download it from the major APP store.
2. Start the MirroSky APP and when prompted, allow the APP to gain access to your photo album and your location. Photo album access is needed to store the images taken from MirroSky. Location data is needed as the SP127 uses the phones GPS location, date, and time to align the telescope. If prompted, select to always connect without internet.
3. Plug the included AC adapter into the wall outlet, and plug the other end into the power port  located on the mount. If preferred, you may use any power bank that supplies 12V power or 8 AA batteries. See Fig. 3.3 & 3.4.



Fig. 3.3



Fig. 3.4

- After being plugged in and the on/off switch pressed, the SP127 performs an auto-home action in the horizontal and vertical directions. When the auto-home action is complete, the OTA should be level. See the section titled Home Position Sensors for more information.

Note: During the auto-home action, the altitude axis only moves in an upward direction to find level. As such, it is recommended to start with the OTA pointed slightly below level or the altitude axis may need to travel almost one full revolution to find it. See the section titled Home Position Sensors for more information.

Connecting to the Telescope

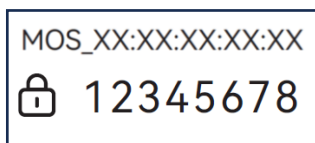

Fig. 3.5

- Open the Wi-Fi setting on your phone or tablet and connect to the Wi-Fi named "MOS_XXXXXXX" by using the password "12345678." See Fig. 3.5.



Fig. 3.6

- Once connected, you should see a green icon located in the upper left corner of the APP home page which states "CONNECTED" See Fig. 3.6

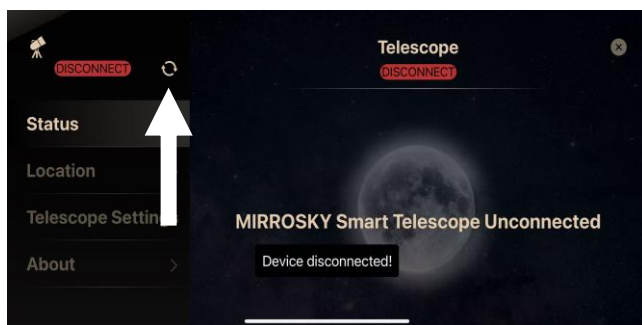

Fig. 3.7

- If the telescope disconnects from the APP or shows "DISCONNECTED" in red, press the telescope icon or press the refresh icon next to the telescope icon, and the telescope will reconnect to the APP. See Fig.3.7

Note: The app might disconnect from the telescope if the phone or tablets lock screen is activated. If this occurs often, try increasing the phone or tablets lockscreen time to prevent it from activating. If the app disconnects often, also confirm you are near the telescope and Wi-Fi connection is strong.



Terrestrial Viewing



To start viewing terrestrial objects, tap the “EXPLORATION” button located on the bottom left of the main screen.

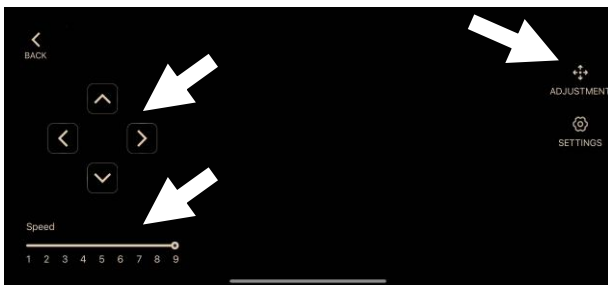

In the “EXPLORATION” page, clicking the “ADJUSTMENT” button enables you to adjust the slewing direction and speed of the telescope. Use the arrows on the left side of the screen to move the telescope in each direction as desired. You can also change the telescope speed by adjusting the speed bar as needed (“1” is the slowest speed and “9” is the fastest).

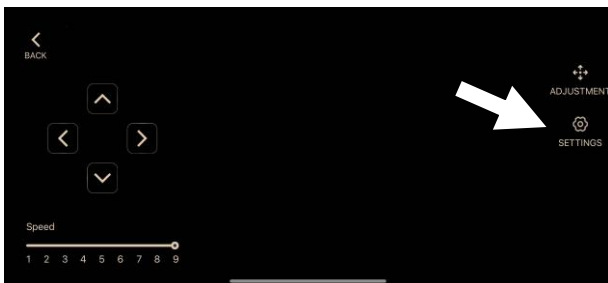

In the “EXPLORATION” page, click the “SETTINGS” button to adjust various camera settings such as the Resolution, Gain, Exposure Time and Crosshair overlay.

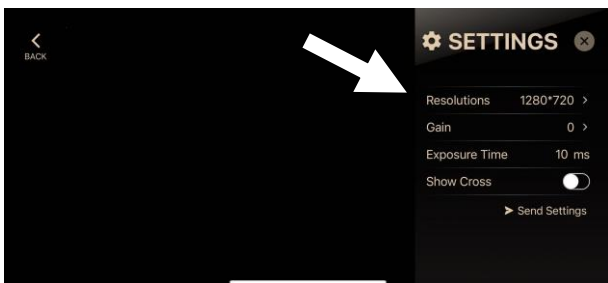

You may change the camera settings for different viewing modes and targets.

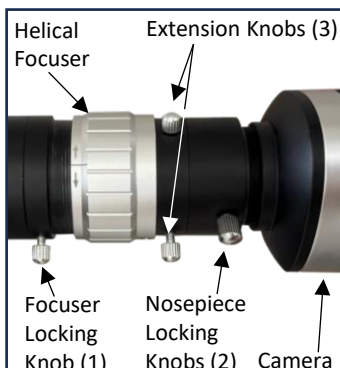

After centering the object you’d like to observe, you may need to fine-tune the telescope focus. If needed, adjust the telescope focus by rotating the silver focuser ring until the target object is as sharp and small as possible.

For a more detailed use of the focuser and achieving focus, please see the section titled “Focusing the OTA” on page 8.



Celestial Viewing / Imaging

To locate celestial objects in the MirroSky APP, you can search for the object by name or select it directly from the sky map. Once selected, you can have the SP mount “GoTo” the object and start imaging it.

Method 1: Name Search



To search for a celestial object, tap the  icon located on the top right corner of the sky map. The object search page will open.

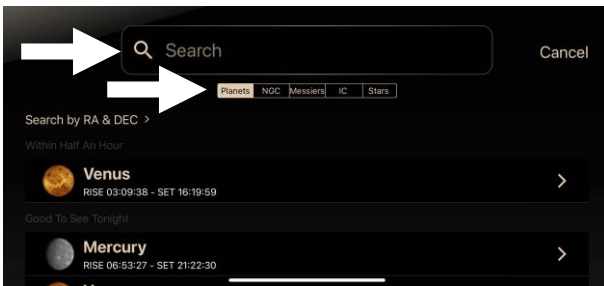

In the search page, enter the Name, NGC, Messier, or IC number of the object you’d like to observe into the search bar.

You may also select the desired object from the object list located under the search bar. Select the object you’d like to observe.

Method 2: Sky Map



To enable the full sky map function, you will need to enable the Gravity Sensor feature. Tap the “Layers” icon  located on the bottom right corner of the sky map.

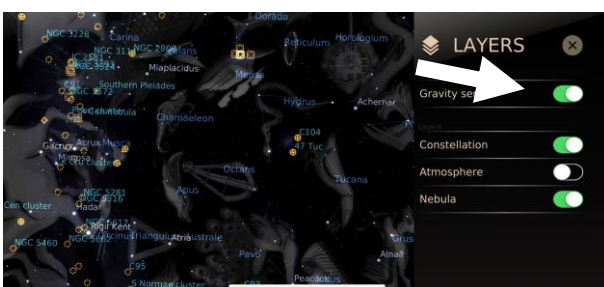

Enable the Gravity Sensor to allow the APP to show the location of the celestial objects in real time when you move the phone or tablet across the sky.

You may also enable or disable the sky map appearance of “Constellation,” “Atmosphere,” or “Nebula” to your preference. Click the object you’d like to observe.

If you know exactly which object you would like to observe, it is recommended to use the “Name Search” method. However, if you would just like to explore a specific part of the night sky, it is recommended to use the “Sky Map” method so you can zoom in and out on the map to locate and select your desired object.



Celestial Viewing / Imaging Continued

After you have selected an object to observe, follow the steps below and the telescope will slew to and start imaging this object.

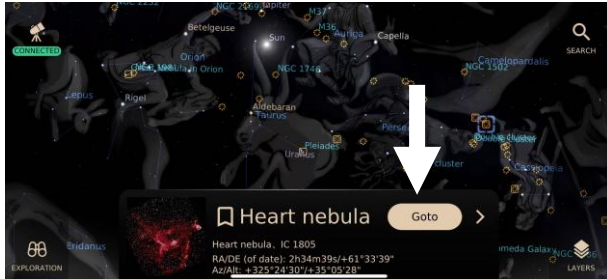

After selecting the object to observe, the coordinates of the object will appear in the bottom of the screen along with a “Goto” icon. Select “Goto” and the telescope will automatically plate solve and center the object in your field of view. This process may take up to 2 minutes.

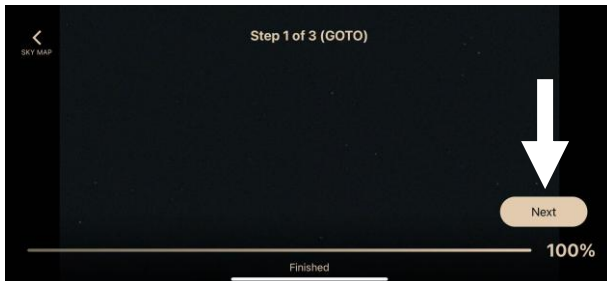

Note the telescope may slew to a different part of the sky to plate solve before slewing to the desired object. If there is an obstacle between the telescope and the object, the plate solve process may need to be redone.

To redo the plate solve process, simply press “Goto” again. When plate solve is complete, press the “Next” icon on the bottom right corner of the screen.

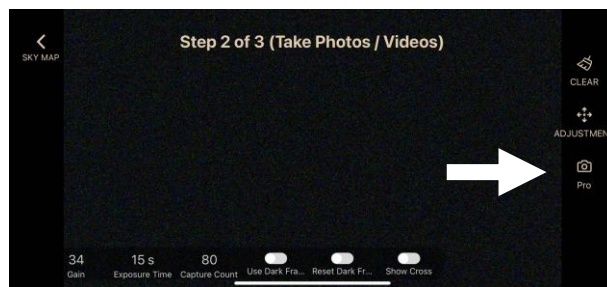



Before taking an image of the object, you may change the camera settings such as the exposure time, number of images taken, gain, and etc. Select the Pro icon to change these settings.

Tip: Exposure time, gain, and image count depend on the target. In general, use the longest exposure and most images possible while keeping gain low. Avoid overly long exposures, as they can cause saturation, field rotation, and star trailing from unwanted movement or poor seeing. Try starting with 10 second (10,000ms) exposures, 34 gain, and 80 images. Adjust as necessary.

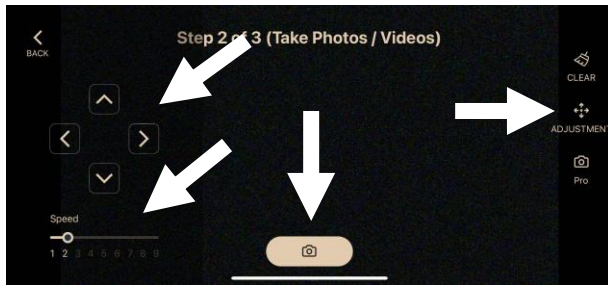

Celestial Viewing / Imaging Continued



You may also move the telescope around through the APP by pressing the “ADJUSTMENT” icon . Please note that while moving the telescope around, the telescope continuously tracks the object so you don't need to worry about losing the target. Once you are done with positioning the object, you may start the imaging process by pressing the camera icon  located at the bottom.

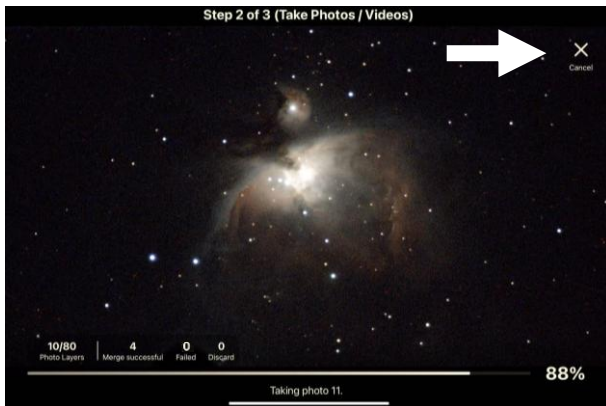

The image begins after pressing the camera icon and the APP starts live-stacking the images. It often takes at least 4 images to start seeing the object detail emerge. As more images are taken and stacked automatically, you will see the object getting brighter and show more detail. You may stop the image taking process anytime by pressing the “Cancel” icon and save the resulting image to your album.



How Dark Frames Improve Image Quality

The MirroSky APP includes a feature for improving image quality by taking dark frame images and subtracting them from the object images. A dark frame is an image taken with the telescope front cover installed and records the camera’s electronic noise, or “dark current”. This inherent noise is temperature dependent and increases with image exposure time. As such, it is best to take dark frames for each exposure time and gain setting used and the MirroSky APP will prompt you when they are needed. We recommend activating the Dark Frame feature for each night sky object imaged.

Another benefit of applying dark frame images is in removing artifacts created by “hot pixels” on the imaging sensor. Hot pixels are pixels that are always in the “on” position and record light non-linearly. When multiple images are stacked together, hot pixels will show as colored streaks as the stacking and image aligning process is adding the hot pixels in each image. Dark frame subtraction does a good job at removing these artifacts and is another reason why dark frames improve image quality.

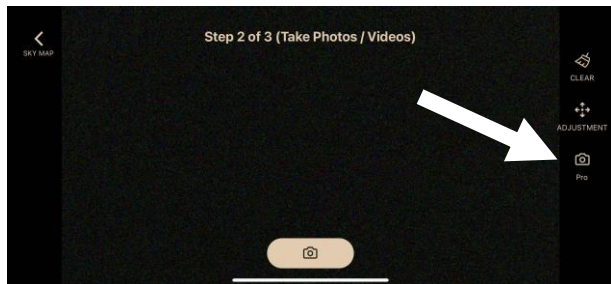

Start with the telescope and Intelligent Camera powered on and connected to the MirroSky APP.

Select the object you want to image and Goto that object. In the APP, select the “PRO” icon on the right side of the screen.

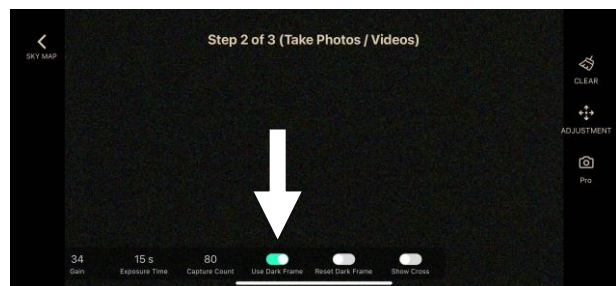

Select the “Use Dark Frame” button at the bottom of the screen

If you already have dark frame images and wish to delete them, select “Reset Dark Frame”.

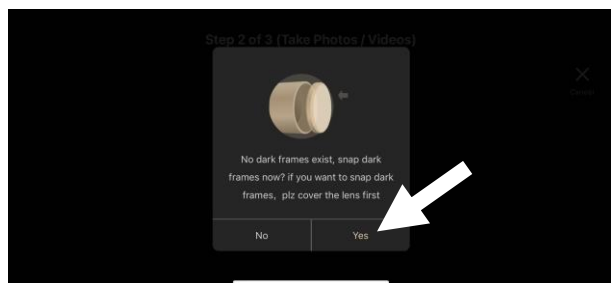

If there are no appropriate dark frames already collected, you will be prompted with instructions on how to proceed.

Cover the front lens on the 53mm OTA with the dust cap. Make sure the dust cap is fully installed to prevent any light from leaking into the telescope and onto the image sensor.

Select the “Yes” button to start taking dark frames.



How Dark Frames Improve Image Quality Cont'd



The MirroSky APP will take 10 dark frames using the same exposure time as used on your target object.

When the MirroSky app is finished taking dark frames, it will prompt you to remove the front lens cover.



Now when you take an image of an object using this exposure time and gain, the dark frames will be automatically subtracted when the “use dark frame” option is selected.

Note: The dark frames collected are only retained in camera memory for each observing session. If power to the telescope is removed, the dark frame images are lost and you will need to retake images on your next observing session.

THE DESKTOP CLIENT

The MirroSky Desktop Client is available to download from the Spectrum Optics website and allows for direct access to the Intelligent Camera System. Currently it is compatible with Windows 10 or later. As the Desktop Client is in development, features will be added when ready. Some features of the Desktop Client include:

- Exporting and deleting raw image files
- Viewing image information
- Updating the Intelligent Camera firmware

To download the MirroSky Desktop Client, scan the QR code below or visit the Spectrum Optics website.

<https://spectrumoi.com/project/mirrosky-series/>







Cleaning the Optics

Your SP127 telescope is a precision instrument built for years of use. With proper care, it will rarely need service and general maintenance can keep the telescope quality in its peak performance. Follow these guidelines to maintain the telescope quality:

- **Avoid Cleaning Optics:** A light layer of dust on the front lens does not significantly affect image quality and usually doesn't require cleaning. If cleaning is required, take note of the recommendations described below.
- **Dust Removal:** When necessary, gently brush or blow off dust with a camel-hair brush, ear syringe, or optical dust blower. Avoid commercial lens cleaners and canned compressed air as they often contain propellants that can spray onto the glass and can be difficult to remove.
- **Removing Smudges:** For fingerprints or organic marks, use a mix of 3 parts distilled water to 1 part isopropyl alcohol, plus one drop of biodegradable dish soap per pint. Use soft, white, unscented facial tissues and light, short strokes. Change tissues frequently. Avoid colored, scented, or lotioned tissues to prevent optical damage. When cleaning any optical surface always use light strokes to avoid scratching the optical coatings.
- **Cleaning Inside Surface:** If the inside of the corrector lens needs cleaning, unthread the front lens cell (which holds the lens and secondary mirror). **Caution:** Never touch the secondary mirror's reflective surface—doing so may scratch it. **Note:** Keep the lens mounted in its metal housing during cleaning to preserve alignment. Do not remove the secondary baffle.
- **After Damp Use:** If used in humidity, wipe external surfaces dry before storage, but do not wipe optical surfaces. Let optics air-dry indoors and keep the dust cap off until fully dry. Otherwise, mold can develop on optical surfaces which can eat away at the optical coatings.
- **Heat Exposure:** Don't leave the telescope in a hot car or direct sunlight for long periods—excessive heat may damage electronics and lubrication. Excessive heat might also soften the adhesive used to attach the secondary mirror baffle causing it to slip out of position. Never point the telescope at or near the sun without certified safe solar filters installed on all open optical tubes or permanent damage will occur to the optics. See the Solar Warning below.
- **Long-Term Storage:** If storing for a month or more, remove the eight AA batteries from the drive base to prevent potential leakage and damage.

 SOLAR WARNING	
<ul style="list-style-type: none"> • Solar observations require SPECIAL PRECAUTIONS to ensure the safety of both your eyes and your equipment. • The Sun emits intense and POTENTIAL HARMFUL RADIATION, including ultraviolet and infrared light. • Observing the Sun without proper solar rated gear can lead to IRREVERSIBLE DAMAGE to your eyes and equipment. 	



Product Name	MirroSky SkyPilot 127 Smart Telescope (SP127)
Primary OTA	<ul style="list-style-type: none"> • 127mm Maksutov-Cassegrain • Focal Length: 1,900mm, F/15 • Optical Coatings: Fully Multi-Coated • Dovetail: Vixen-Style • Length: 14.6" (370mm) • Weight: 6.5 lbs. (2.95kg)
	Eyepiece Plossl 25mm, 1.25"
	Eyepiece Magnification 76x
	Diagonal Mirror 90 degree, 1.25"
	Limiting Stellar Magnitude 13.2
	Limiting Resolution 0.91 arc-seconds
	Assembled Weight 26 lbs (11.8kg)
	Mount Payload Capacity Approx. 9 lbs. (4kg)
Guide Scope OTA	<ul style="list-style-type: none"> • 53mm ED Refractor with Helical Focuser • Focal Length: 200mm, F/4 • Optical Coatings: Fully Multi-Coated • Field of View w/ Intelligent Camera: 1.6 deg x 0.9 deg (approx.)
	Dovetail Universal Viewfinder-style
	<ul style="list-style-type: none"> • Sony IMX662 CMOS color sensor • Pixel Size: 2.9µm • Resolution: 1920 (H) x 1080 (V) • 64GB onboard storage • ADC: 12 bit • No Amp glow • Ports for Power (USB-C), USB 2.0, ST4
	Wi-Fi Band 2.4 & 5 GHz
	Software Application MirroSky APP (available on iOS and Android)
	Astronomical Database Over 100,000 objects
SP Mount	
	Mount Configuration Alt/Azimuth
	Motor Stepper Motor
	Altitude Gear worm gear drive
	Azimuth Gear worm gear drive
	Max Slew Speed 3 degrees per second
	Tracking Modes 9 speeds
	Compass Built-in geomagnetic compass
	GPS Location information received through MirroSky App
	Working Mode Alt/Az
	Power Input DC 12V 2A or user-supplied 8AA batteries
Tripod	Adjustable full-size tripod with 1.5" diameter steel legs Accessory Holder with spots for 1.25" accessories



Thank you for choosing Spectrum Optics as your trusted source for telescopes, microscopes and other optical products. We stand behind the quality of our products and offer a TWO-YEAR limited warranty from the date of purchase within the US. If a defect is identified on a new product, Spectrum Optical Instruments will repair or replace a product with proof of original purchase. Please note that this warranty only applies to the original purchaser and it is not transferable. Any product that is purchased from anyone or organization other than Spectrum Optical Instruments or authorized dealer is not covered in this warranty.

Additionally, this warranty does NOT cover damage caused by misuse, mishandling, unauthorized repairs, or normal wear and tear. Spectrum Optical Instruments specifically disclaims special, indirect, or consequential damages or lost profit which may result from a breach of this warranty. Any implied warranties which cannot be disclaimed are hereby limited to a term of two years from the date of original retail purchase.

Spectrum Optics shall use reasonable efforts to repair or replace any product covered by this warranty within thirty days of receipt. In an event where repairing or replacement would require more than thirty days, Spectrum Optics shall notify the customer in advanced. Spectrum Optical Instruments reserves the right to replace any obsolete product with a new product of comparable price and performance.

Spectrum Optics reserves the right to change product specifications or to discontinue products without notice. This warranty gives specific rights. You may have other rights which vary from state to state. For warranty inquires, please contact: customer@spectrumoi.com

RETURN POLICY

As a condition to the obligation to repair or replace your product, the product needs to be returned to Spectrum Optical Instruments with proof of original purchase from Spectrum Optical Instruments or an authorized dealer.

A claim is required to be filed before return of a product. A claim template can be obtained from Spectrum Optical Instruments by email. Please contact customer service at customer@spectrumoi.com in such an event. Each return product must include a written statement detailing the nature of the claimed defect. As well as the original purchaser's name, address, and contact information.

Buyers are responsible for return shipping and handling cost for warranty services after 30 days of original purchase. Our warranty covers parts and labor only.

Spectrum Optics reserves the right to replace an obsolete product with a new product of comparable price and performance. In event of a defected product shall be replaced by a new product, the defected product become the property of Spectrum Optics. Spectrum Optics does not issue refunds but only repair or replacement.

CUSTOMER SERVICE

US-based team, Lightning-fast Response

When you reach out to us, you're not just getting assistance; you're connecting with a team of professional experts right here in California. We're proud to be based in the USA, and we stand by our commitment to provide you with answer and support within 24 hours. Your questions and concerns are our top priority.

Email us: customer@spectrumoi.com
Call us: (888) 879-5143
Visit our website: www.spectrumoi.com

